



Vysokorychlostní sítě 2001

Hodnotenie kvality VoIP

Žilinská univerzita

Katedra informačných sietí

Martin Klimo

martin@frkis.utc.sk



Kvalita služby

ITU-T odporúčanie E.800

súhrnný efekt poskytovania služby, ktorý určuje stupeň spokojnosti používateľa služby



Subjektívne hodnotenie kvality

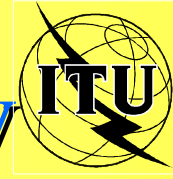

MOS - Mean Opinion Score

Známka dojmu	Vyjadrenie kvality
5	výborná (excellent)
4	dobrá (good)
3	uspokojivá (fair)
2	neuspokojivá (poor)
1	zlá (bad)

V minulosti tiež – Excellent = 4, Good = 3, Fair = 2, Poor = 1, Bad = 0



Štruktúra kvality

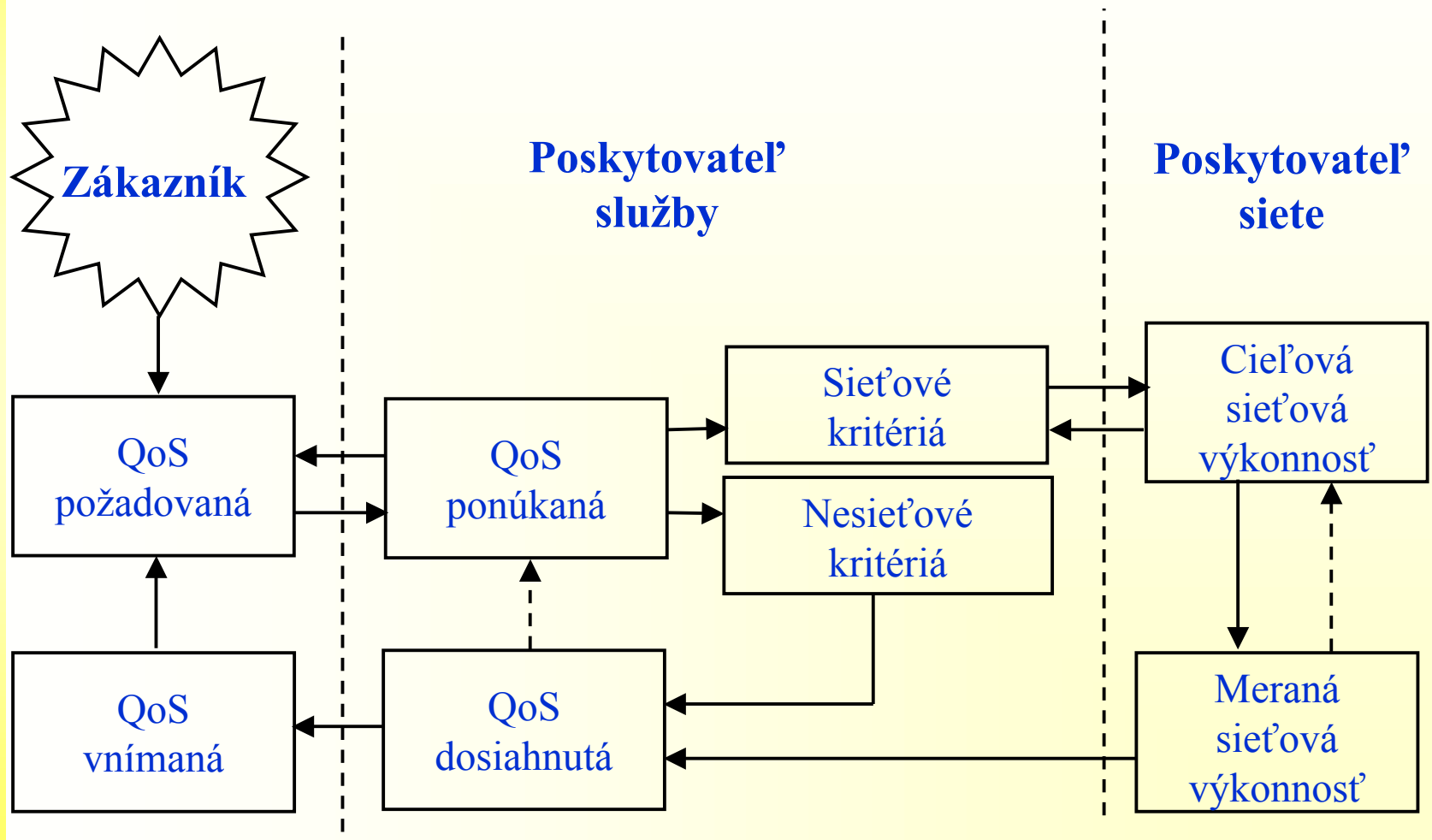



Prepočet QoS-NPP

Miera kvality

QoS parametre

MOS

???

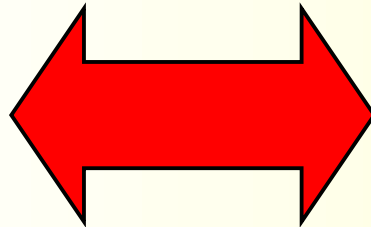

Sieťová výkonnosť

NP parametre

Prenosová rýchlosť

Chybovosť

Šírka pásma

Oneskorenie

Tlmenie

Odmietnutie spojenia

⋮



Vplyv šírky pásma

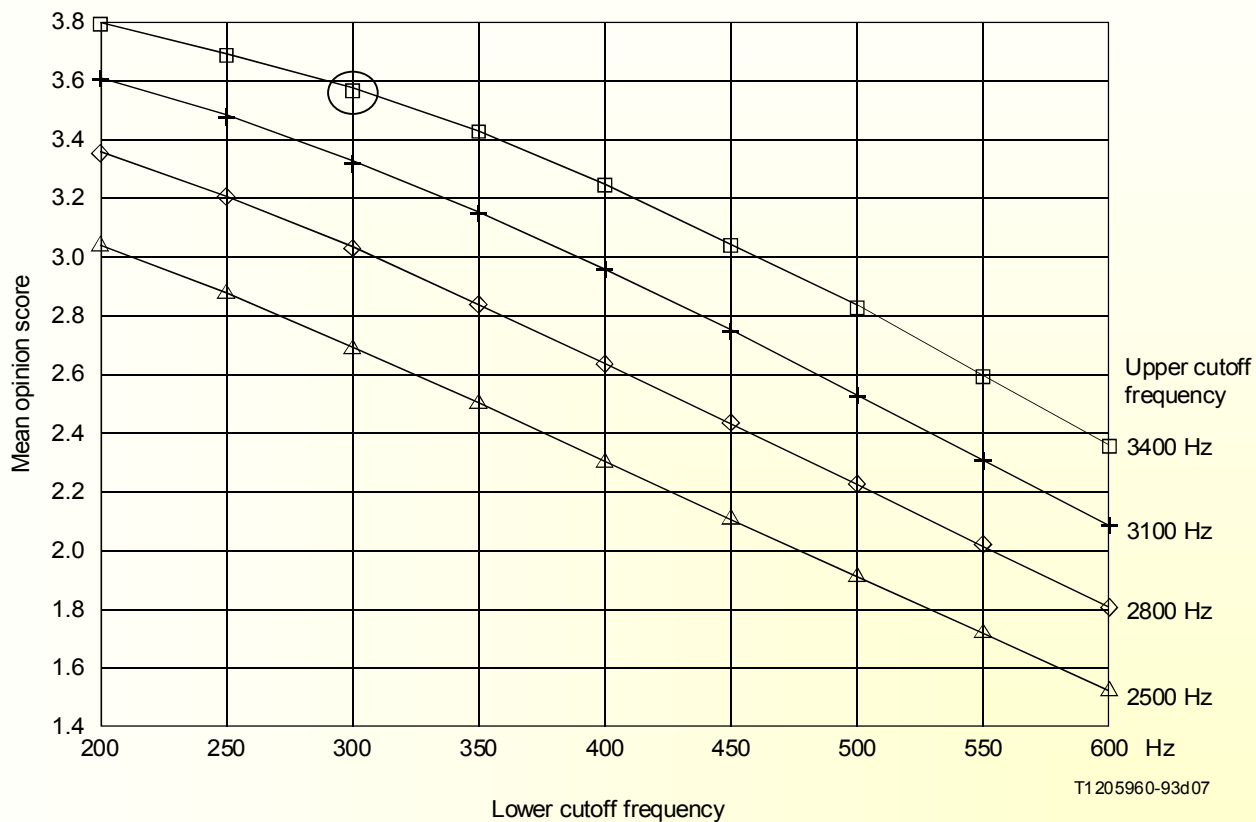

FIGURE A.6/P.11

Mean opinion score as a function of lower and upper cutoff frequencies



Objektívne hodnotenie kvality

Jednosmerný prenos

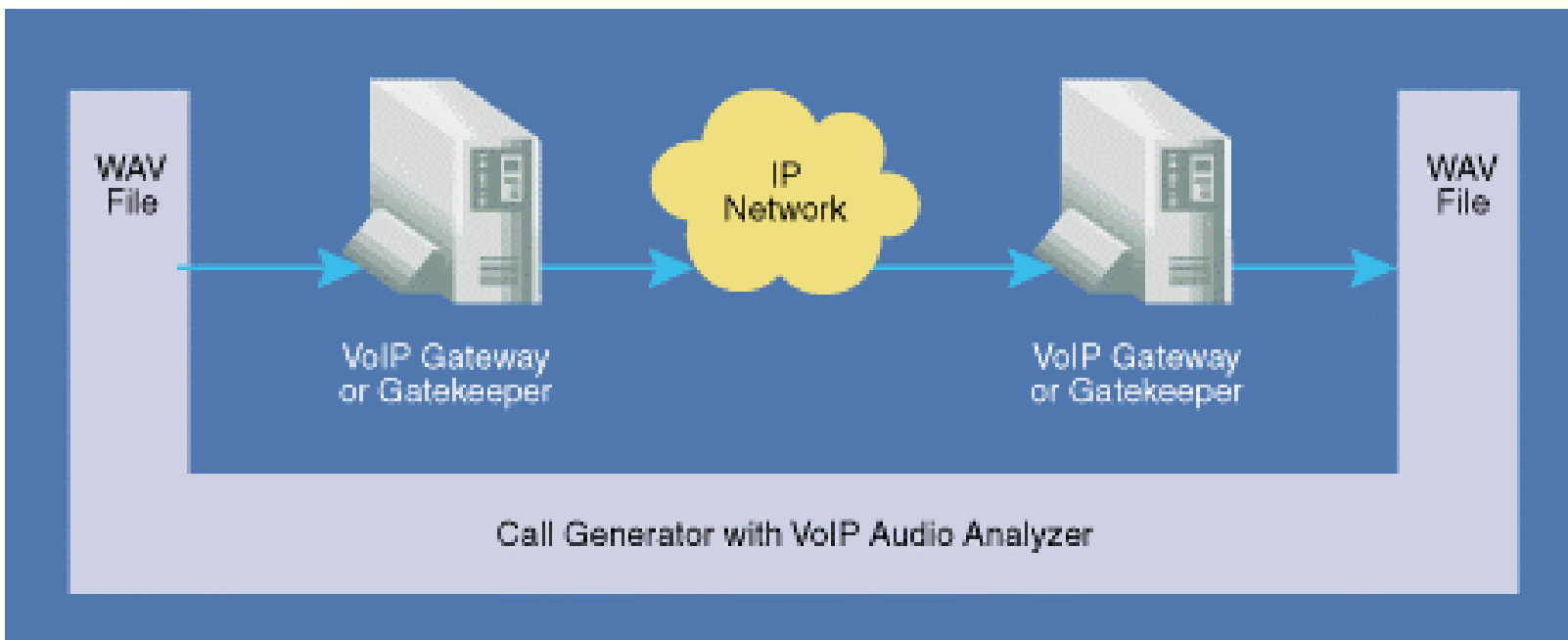



Objektívne hodnotenie kvality

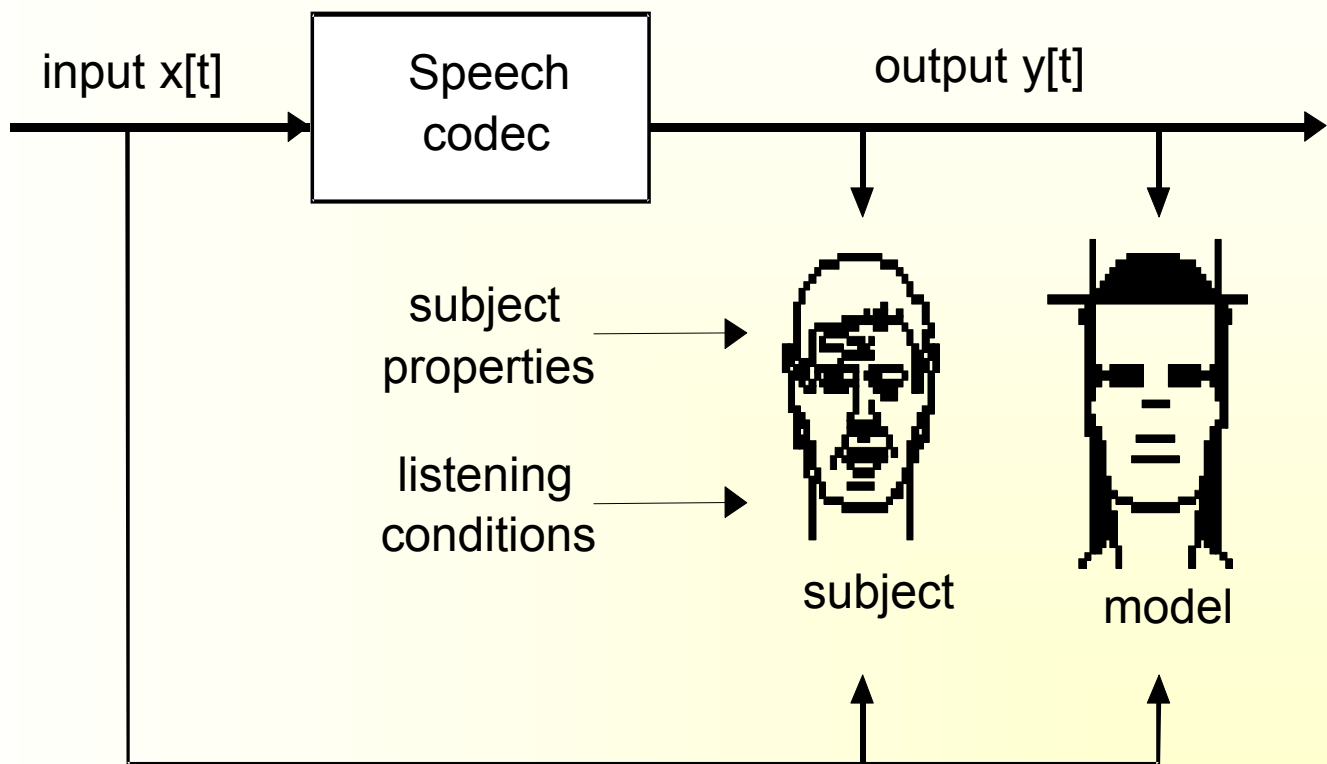



Perceptual Speech Quality Measurement ITU-T Rec. P.861

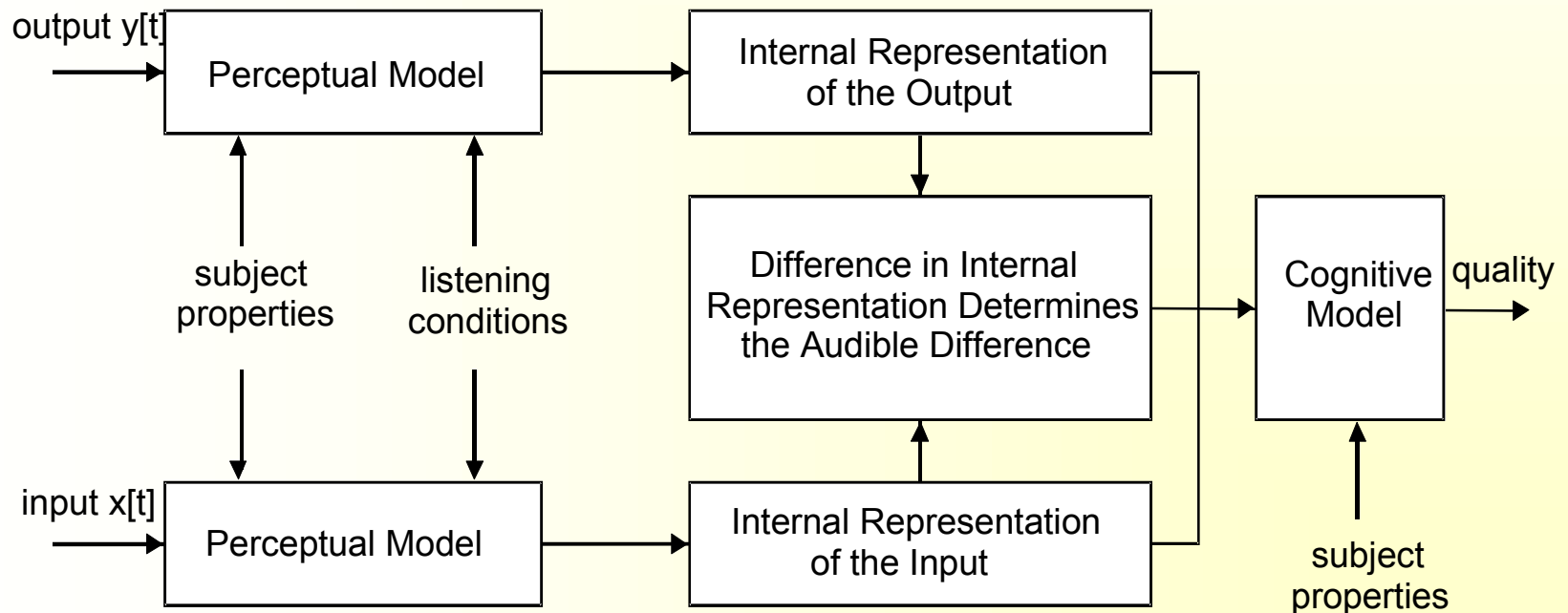



Testéry QoS

PSQM:

Hammer Technologies

OPTICOM – aj PSQM+

RADCOM – aj PAMS

Zarak Systems Corp.

Telegra - aj PSQM+, PAMS

GRAYSON Wireless

SAGE Instruments

Comarco Wireless Technologies

LCC – aj PSQM+, PSQM++, AURYST, VQM



Objektívne hodnotenie kvality



Dvojsmerný prenos

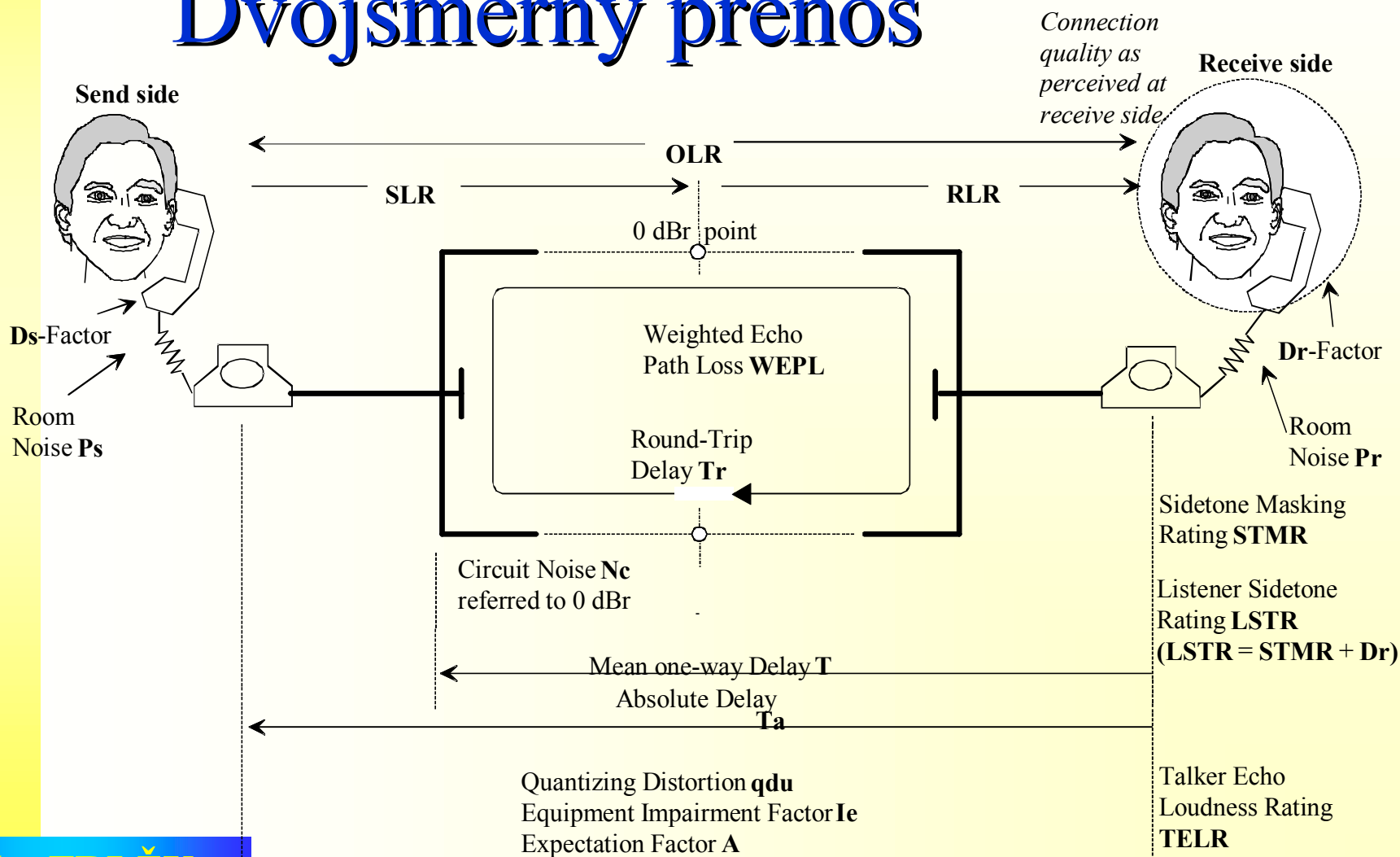



Overall Rating R

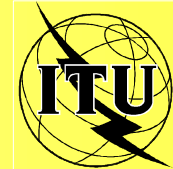

R-Value Range	Speech Transmission Quality Category	User Satisfaction
$90 < R < 100$	Best	Very satisfied
$80 < R < 90$	High	Satisfied
$70 < R < 80$	Medium	Some users dissatisfied
$60 < R < 70$	Low	Many users dissatisfied
$50 < R < 60$	Poor	Nearly all users dissatisfied



Overall Rating R

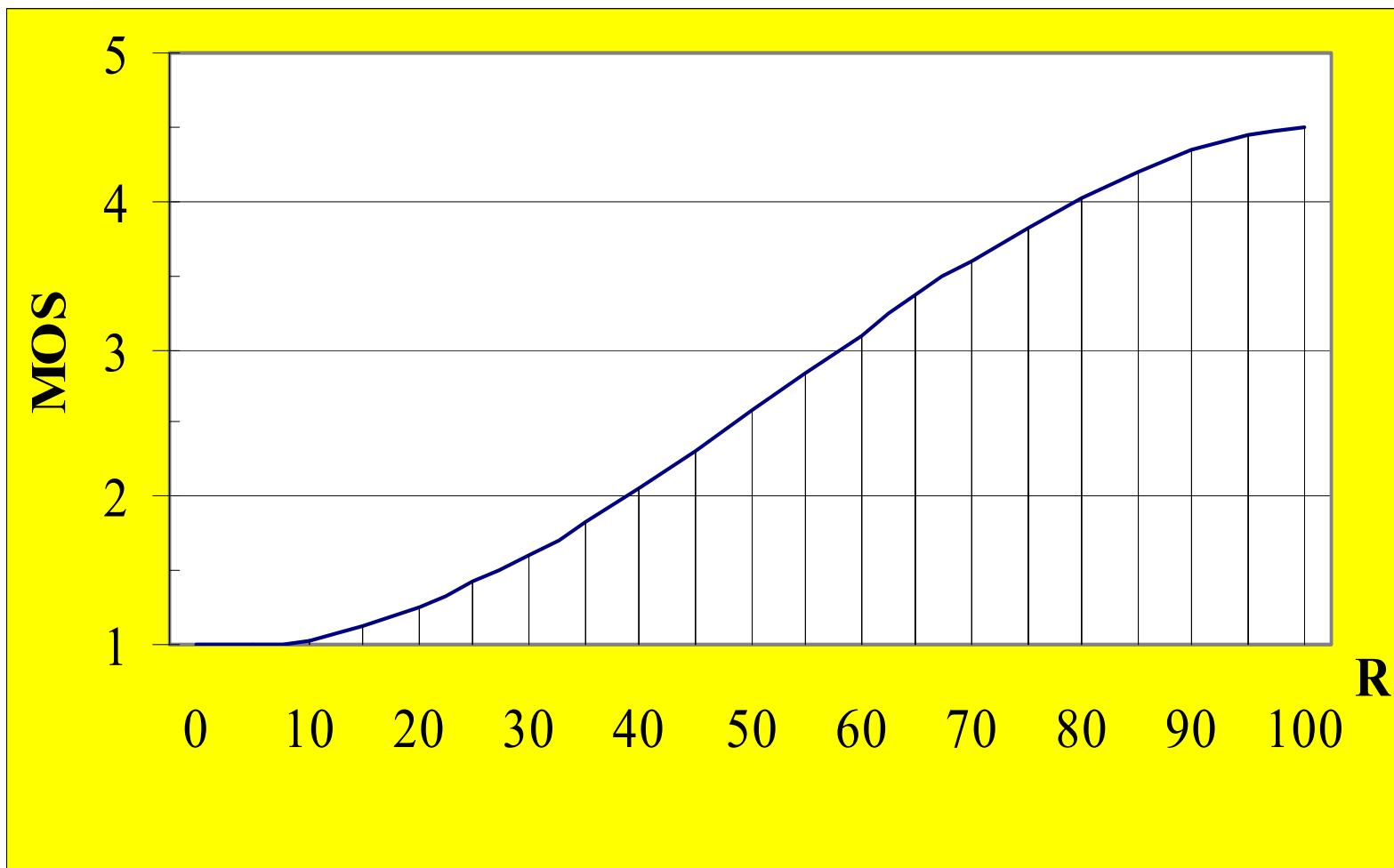
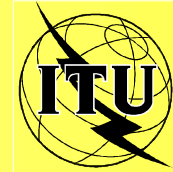

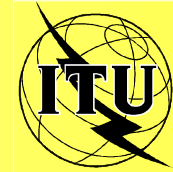

Overall Rating R

Overall Rating R (ITU-T Rec. G.109)

E-model (ITU-T Rec. G.107)

$$R = R_o - I_s - I_d - I_e + A$$

R_o - sources generating noise independently on the speech

I_s - all impairments which occur simultaneously with the speech

I_d - impairments caused by delay

I_e - impairments caused by low bit rate codecs

A - expectation factor



R - Meter

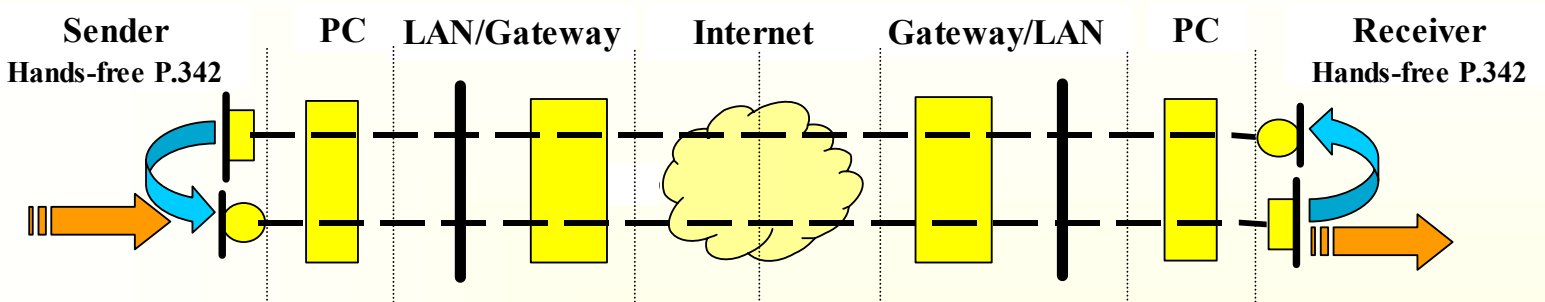

Transmission Rating Factor R (ITU-T Rec. G.109)

$$R = R_o - I_s - I_d - I_e + A$$

$$88 = 87 - 0 - 4 - 6 + 10$$

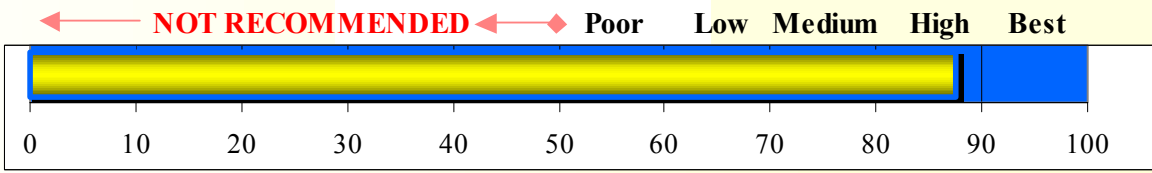

Mean Opinion Score MOS (ITU-T Rec. P.800)

MOS= 4,3

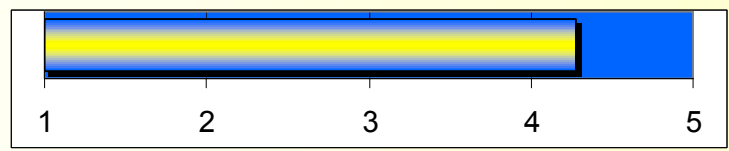



R - Meter



Default Values

Delay Impairment Factor I_d

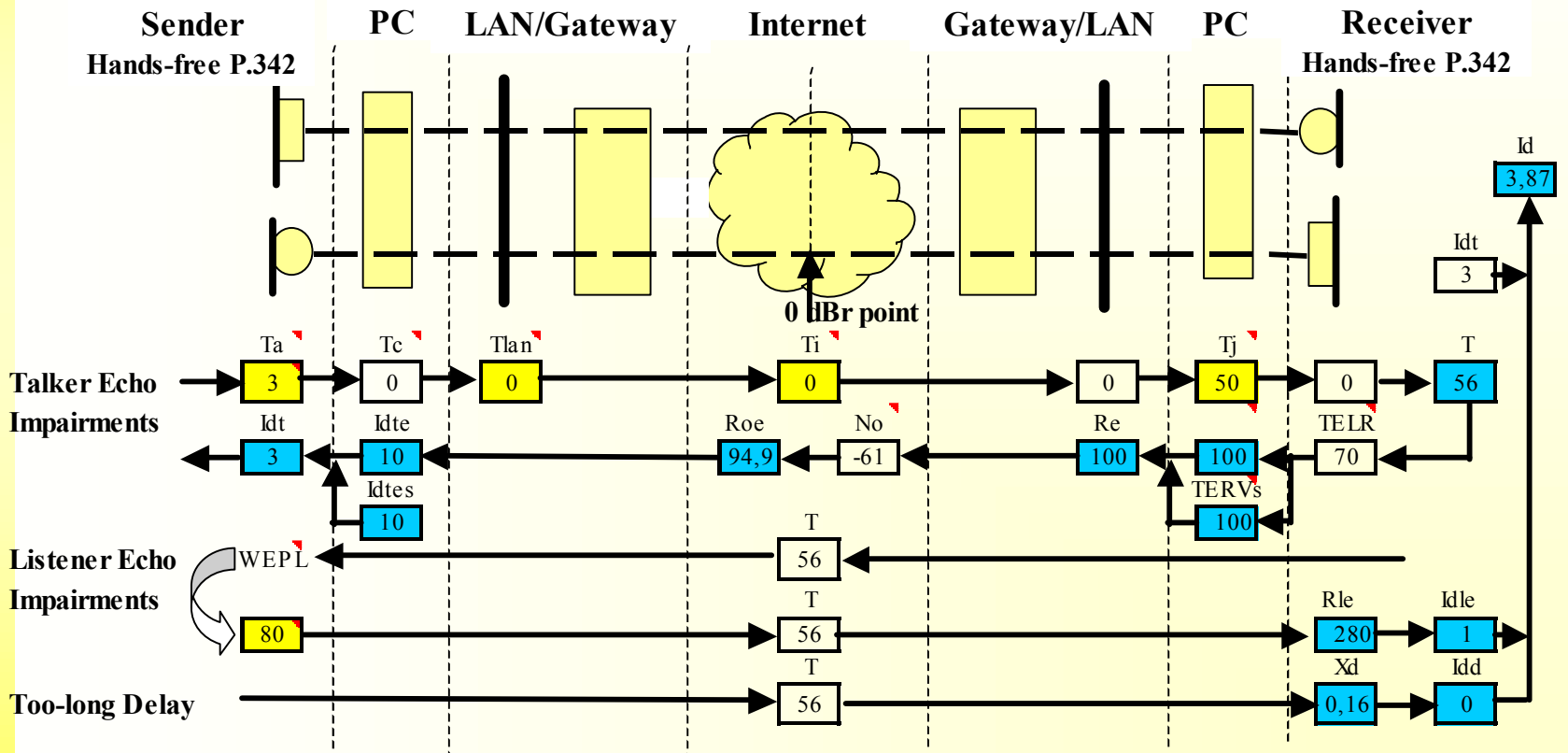



Packet loss impact $MOS=f(p_1)$

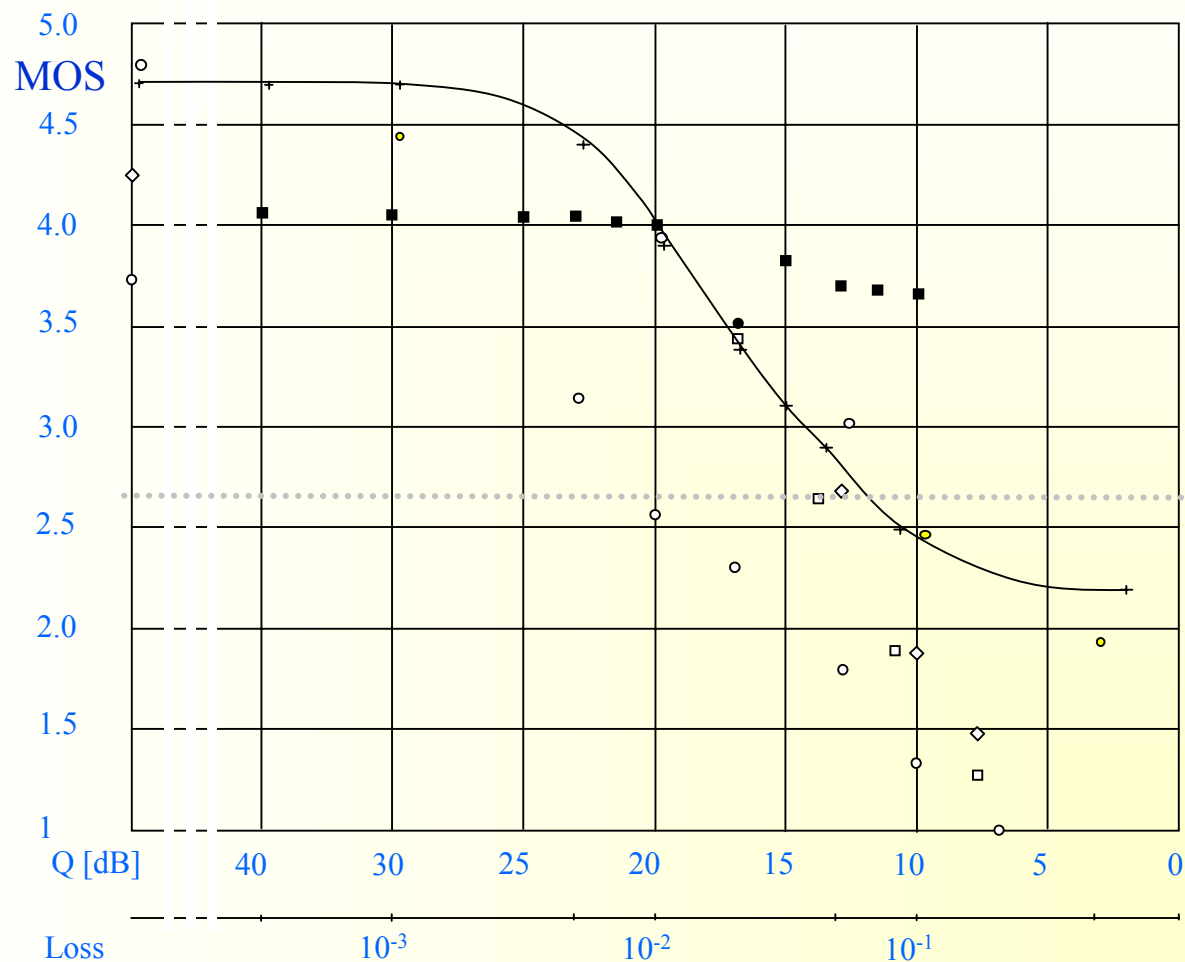



Delay

- minimum delay
- 50th percentile delay
- 90th percentile delay

France Telecom to Advanced

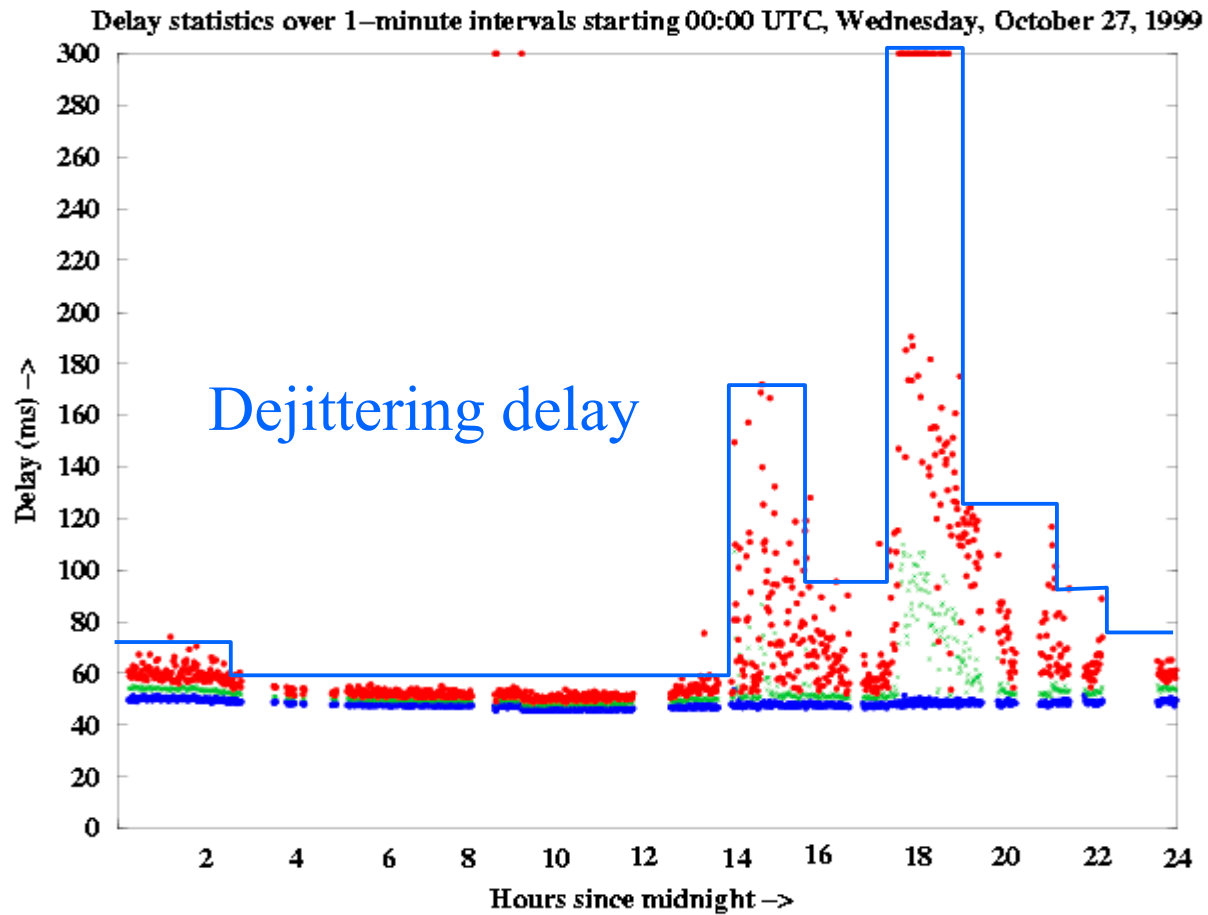



Packet Loss

France Telecom to Advanced

Packet Loss statistics over 1-minute intervals starting 00:00 UTC, Wednesday, October 27, 1999

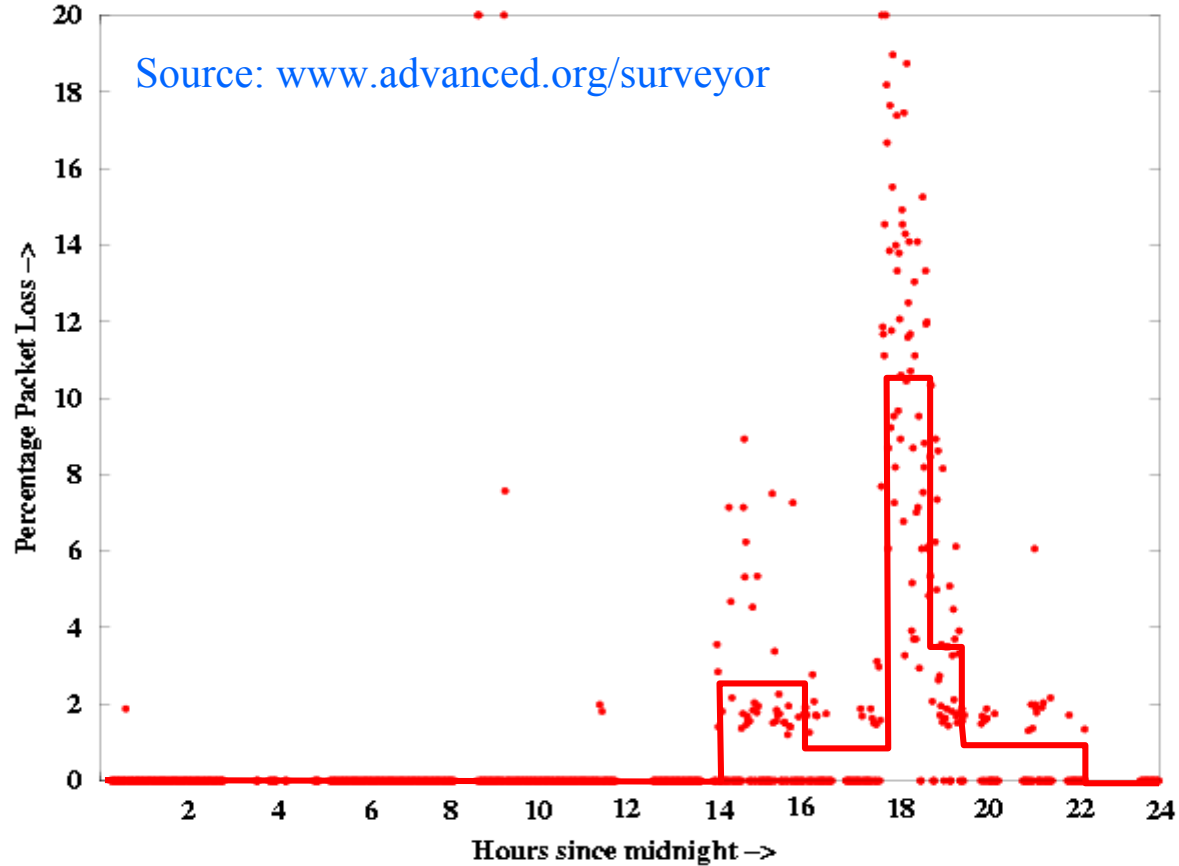



France Telecom to Advanced

R – Values starting 00:00 UTC, Wednesday, October 27, 1999

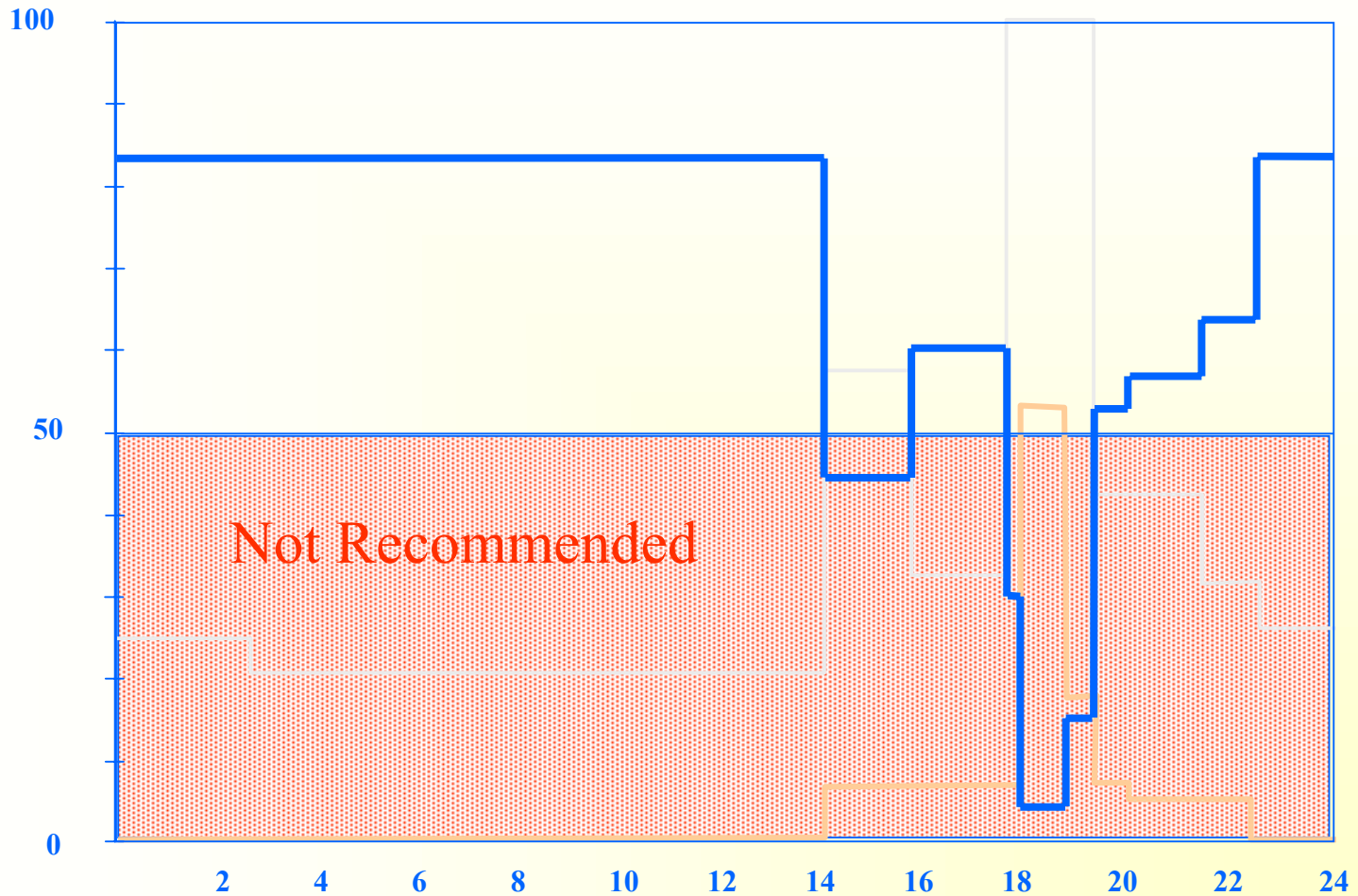

Hands-free P.342, coding G.711, default values G.175



Vysokorychlostní síť 2001

Ďakujem za pozornosť

Martin Klimo

martin@frkis.utc.sk